

TM 11-6625-1702-35

DEPARTMENT OF THE ARMY TECHNICAL MANUAL

DS, GS, AND DEPOT MAINTENANCE MANUAL

TEST SET, ANTENNA AN/ARM-115

This copy is a reprint which includes current pages from Changes 1 through 3. Title was changed by Change 3.

HEADQUARTERS, DEPARTMENT OF THE ARMY
MAY 1968

WARNING!

Be careful when working on the 115-volt ac line connections. DEATH or SERIOUS INJURY may result from contact with these terminals.

DON'T TAKE CHANCES!

CAUTION!

Do not make resistance measurements with power applied to Test Set, Antenna AN/ARM-115. Do not make resistance measurements that would place the multimeter across test set meter M1 in AN/ARM-115.

**DS, GS, AND DEPOT MAINTENANCE MANUAL
 TEST SET, ANTENNA AN/ARM-115
 (NSN 6625-00-935-4293)**

	Paragraph	Page
CHAPTER 1. FUNCTIONING		
SECTION I. Introduction		
Scope	1-1	1-1
Indexes of publications	1-2	1-1
Forms and records	1-2.1	1-1
Reporting of errors	1-2.2	1-1
Reporting equipment improvement recommendations (EIR)	1-2.3	1-1
Administrative storage	1-2.4	1-1
Destruction of Army electronics materiel	1-2.5	1-1
II. Block Diagram Functioning		
General block diagram functioning	1-3	1-1
Power control block diagram	1-4	1-2
0-to 500-millivolt power supply block diagram	1-5	1-2.1
Meter block diagram	1-6	1-2.1
Tune indicator block diagram	1-7	1-2.1
III. Detailed Circuit Functioning		
General circuit functioning	1-8	1-2.1
Power control circuit	1-9	1-3
0-to 500-millivolt power supply circuit	1-10	1-3
Meter circuit	1-11	1-5
Tune indicator circuit	1-12	1-6
CHAPTER 2. TROUBLESHOOTING		
SECTION I. General Troubleshooting Techniques		
General instructions	2-1	2-1
Organization of troubleshooting procedures	2-2	2-1
Test equipment required	2-3	2-2
II. Troubleshooting Procedures		
Bench test setup	2-4	2-2
Localizing troubles	2-5	2-2
Waveform analysis	2-6	2-6
Isolating troubles	2-7	2-6
CHAPTER 3. REPAIRS AND ALIGNMENT		
General parts replacement techniques	3-1	3-1
Removal of test panel from test set case	3-2	3-1
Removal of test panel dust cover	3-3	3-1
Removal of RF directional power sensor Z1	3-4	3-1
Removal of component board A1	3-5	3-1
Removal of METER FUNCTIONswitch S3	3-6	3-1
Removal of RF SELECT switch S1	3-7	3-1
Replacement of RF SELECT switch S1	3-8	3-1
Replacement of METER FUNCTION switch S3	3-9	3-2
Replacement of component board A1	3-10	3-2
Replacement of dust cover	3-11	3-2
Replacement of test panel	3-12	3-2
Equipment adjustments	3-13	3-2
Alignment	3-14	3-2

	Paragraph	Page
CHAPTER 4. GENERAL SUPPORT TESTING PROCEDURES		
General	4-1	4-1
Test equipment, tools, and materials	4-2	4-1
Test facilities	4-3	4-1
Physical tests and inspection	4-4	4-1
Dc meter scale test	4-5	4-2
Millivolt source test	4-6	4-3
TUNE INDICATOR function test	4-7	4-5
Coupler test	4-8	4-6
Rf wattmeter test	4-9	4-7
Antenna element test	4-10	4-8
Test data summary	4-11	4-8
CHAPTER 5. DEPOT OVERHAUL STANDARDS		
Applicability of depot overhaul standards	5-1	5-1
Applicable references	5-2	5-1
Test procedures	5-3	5-1
APPENDIX A. REFERENCES		A-1

CHAPTER 1 FUNCTIONING

Section I. INTRODUCTION

1-1. Scope

a. This manual contains direct support (DS), general support (GS), and depot maintenance instructions for Test Set. Antenna AN/ARM-115. It includes instructions for troubleshooting, testing, and repairing the test set. It also lists tools, test equipment, and materials required for maintenance. Detailed circuit functioning is covered in paragraphs 1-8 through 1-12.

b. The complete technical manual for the test set includes TM 11-6625-1702-12.

1-2. Indexes of Publications

a. *DA Pam 310-4*. Refer to the latest issue of DA Pam 310-4 to determine whether there are new editions, changes, or additional publications pertaining to the equipment.

b. *DA Pam 310-7*. Refer to DA Pam 310-7 to determine whether there are modification work orders (MWO's) pertaining to the equipment.

1-2.1. Forms and Records

a. *Reports of Maintenance and Unsatisfactory Equipment*. Maintenance forms, records, and reports which are to be used by maintenance personnel at all maintenance levels are listed in and prescribed by TM 38-750.

b. *Report of Packaging and Handling Deficiencies*. Fill out and forward DD Form 6 (Packaging Improvement Report) as prescribed in AR 700-58/NAVSUPINST 4030.29/AFR 71-13/MCO P4030.29A, and DSAR 4145.8.

c. *Discrepancy in Shipment Report (DISREP) (SF 361)*. Fill out and forward Discrepancy in Shipment Report (DISREP) (SF 361) as pre-

scribed in AR 55-38/NAVSUPINST 4610.33A/AFR 75-18/MCO P4610.19B and DSAR 4500.15.

1-2.2. Reporting of Errors

You can help improve this manual by calling attention to errors and by recommending improvements and stating your reasons for the recommendations. Your letter or DA Form 2028 (Recommended Changes to Publications and Blank Forms) should be mailed direct to Commander, US Army Electronics Command, ATTN: DRSEL-MA-Q, Fort Monmouth, NJ 07703.

1-2.3. Reporting Equipment Improvement Recommendations (EIR)

EIR will be prepared using DA Form 2407 (Maintenance Request). Instructions for preparing EIR's are provided in TM 38-750, The Army Maintenance Management System. EIR's should be mailed directly to Commander, US Army Electronics Command, ATTN: DRSEL-MA-Q, Fort Monmouth, NJ 07703. A reply will be furnished directly to you.

1-2.4. Administrative Storage

Administrative storage of equipment issued to and used by Army activities shall be in accordance with TM 740-90-1.

1-2.5. Destruction of Army Electronics Materiel

Destruction of Army electronics materiel to prevent enemy use shall be as prescribed in TM 750-2442.

Section II. BLOCK DIAGRAM FUNCTIONING

1-3. General Block Diagram Functioning

The test set is used to perform complete operational checks and adjustments of the 437S-1/1A VHF/FM Blade Antenna hereafter referred to as the *antenna under test*. The test set provides

the controls and indicators that are necessary to operate and test the antenna under test and also provides a ground plane for operational tests. Test results are indicated by a meter on the front panel and also be observed on an oscilloscope connected to the test set. Paragraphs 1-4

TM 11-6625-1702-35

through 1-7 contain a functional block diagram description of the test set, supported by the block diagram shown in figure 1-1. See figure 6-3 for the overall schematic diagram of the test set.

1-4. Power Control Block Diagram

A 28-volt direct current (dc) input and a

radiofrequency (RF) signal are externally applied to the power control circuits of the test set. RF power is applied through directional power sensor Z1 and RF SELECT switch S1 to the antenna under test. Power of 28 volts dc is supplied through MANUAL TUNE switch S2 to the antenna under test. The power control circuit also supplies 28-volt dc power

to TUNE INDICATOR lamp DS1, microammeter M1, and the 0- to 500-millivolt (mv) power supply.

1-5. 0- to 500-Millivolt Power Supply Block Diagram

The 28-volt dc signal, applied to the 0-to 500-millivolt power supply, is voltage-regulated by Zener diode CR1 and applied to MV ADJUST variable resistor R1A and R1B. Adjustment of R1A and R1B provides a means of regulating the 0- to 500-millivolt output under load conditions. The 0- to 500-millivolt output supplies operating power to the antenna under test.

1-6. Meter Block Diagram

The meter circuit of the test set is controlled

by METER FUNCTION switch S3. When S3 is set to the appropriate position, microammeter M1 indicates the dc supply voltage, the forward and reflected RF power, or the output of the 0- to 500-millivolt power supply.

1-7. Tune Indicator Block Diagram

When tuning of the antenna under test is activated, a motor pulsing signal is applied to the tuning indicator circuit composed of transistors Q1, Q2, and Q3. The motor pulsing signal biases the transistors so that TUNE INDICATOR lamp DS1 lights, indicating that the antenna under test is tuning.

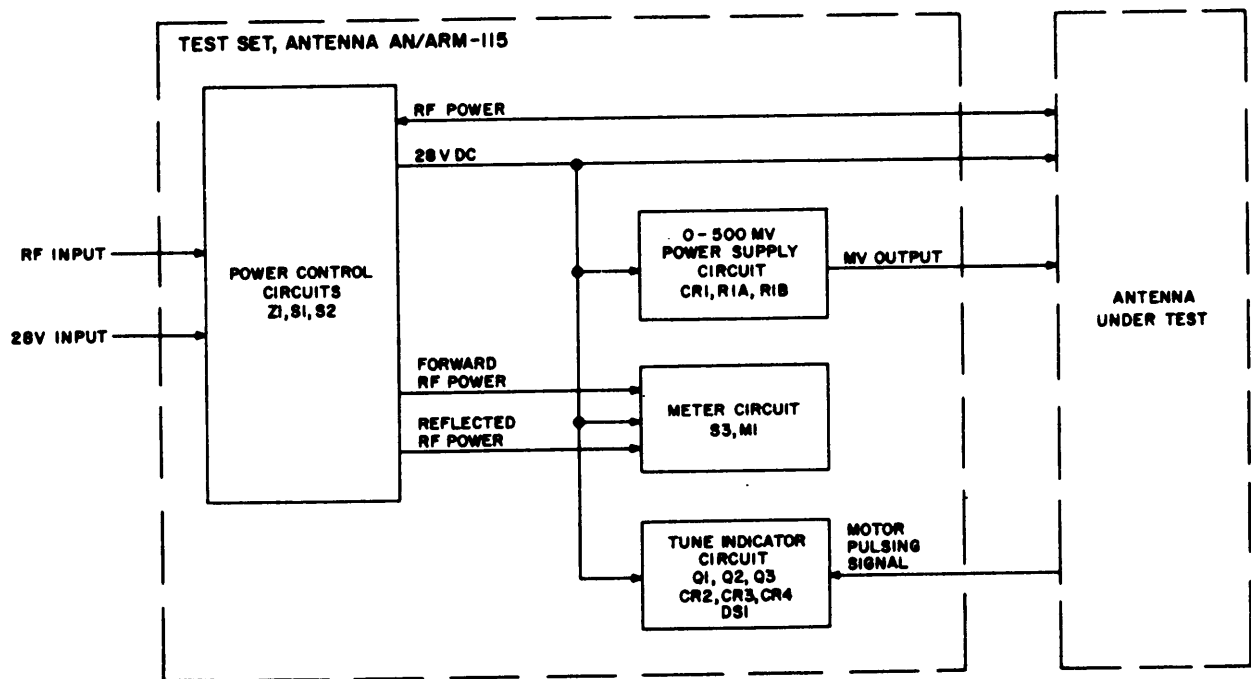

TM6625-1702-35-1

Figure 1-1. Test set, block diagram.

Section III. DETAILED CIRCUIT FUNCTIONING

1-8. General Circuit Functioning

The test set contains a 0- to 500-millivolt power supply, a metering circuit, a tune indicator circuit, and a power control circuit. Para-

graphs 1-9 through 1-12 discuss the functioning of each of the circuits. See figure 5-3 for the overall schematic diagram of the test set.

1-9. Power Control Circuit

(fig. 1-2)

The power control circuit of the test set provides interconnection of rf power, dc power, and common leads to the RF and control output jacks and plugs. RF SELECT switch S1 and MANUAL TUNE switch S2 control the antenna under test.

a. RF power is supplied by an external source to RF INPUT jack J3. The RF power is connected from J3 through directional power sensor Z1 to RF SELECT switch S1. The RF power is supplied through the RF SELECT switch to either P1 or J2. Plug P1 supplies RF power to the antenna under test when the unit is mounted on the test panel. Jack J2 supplies RF power through the RF interconnect cable to the antenna under test when the unit is mounted on a ground plane.

b. Dc power is supplied by an external source to 28V INPUT (+) and 28V INPUT (-) jacks E1 and E2, respectively. The +28-volt input at E1 is applied through fuse F1 to the antenna under test, tuning indicator DS1, test set meter M1 through resistor R2, and the 0- to 500-millivolt power supply.

c. MANUAL TUNE switch S2 provides a ground control for operating the manual tune circuits of the antenna under test. The 28-volt power input, the dc common, and MANUAL TUNE switch S2 supply dc control power to P2 and J4. Plug P2 supplies dc control power to the antenna under test when the unit is

mounted on the test panel. Jack J4 supplies dc control power through a control interconnect cable to the antenna under test when the unit is mounted on a ground plane.

1-10. 0- to 500-Millivolt Power Supply**Circuit**

(fig. 1-3)

The 0- to 500-millivolt power supply consists of load resistor R4, voltage regulator CR1, and voltage divider R5, R1A, and R1B. The +28-volt dc input is regulated to +12 volts dc by R4 and CR1. The regulated 12 volts is supplied across R5, R1A, and R1B where a 0- to 500-millivolt signal is isolated from ground by a 0- to 500-millivolt common connected between R1A and R1B. Resistor R1A is used to supply the + 0- to +500-millivolt signal (voltage drop from R1A center tap to the 0- to 500-millivolt common). Resistor R1B is used to supply the - 0- to - 500-millivolt signal (voltage drop from R1B center tap to the 100-millivolt common). The 0- to 500-millivolt common is supplied to MV OUTPUT COMMON jack E4. The 0- to +500-millivolt signal is supplied to S3C-7, and the -0- to -500-millivolt signal is supplied to S3C-8. The desired polarity is selected by using S3 and the \pm 0- to \pm 500-millivolt signal is supplied by S3C-12 to MV OUTPUT \pm jack E3. Adjustment of R1A and R1B permits adjusting the 0- to 500- millivolt output under loaded conditions.

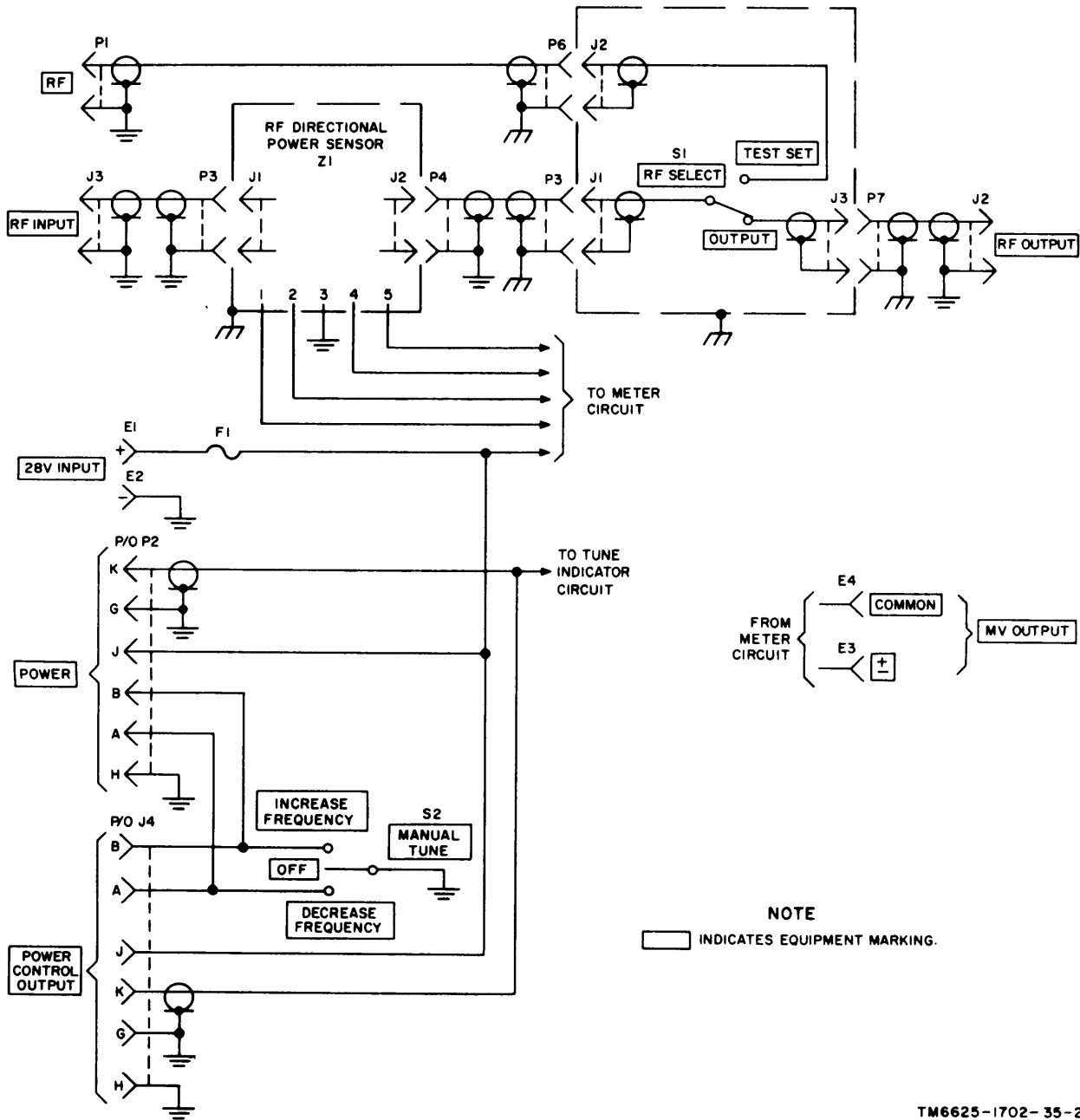

NOTE
 [] INDICATES EQUIPMENT MARKING.

TM6625-1702-35-2

Figure 1-2 Power control circuit, schematic diagram.

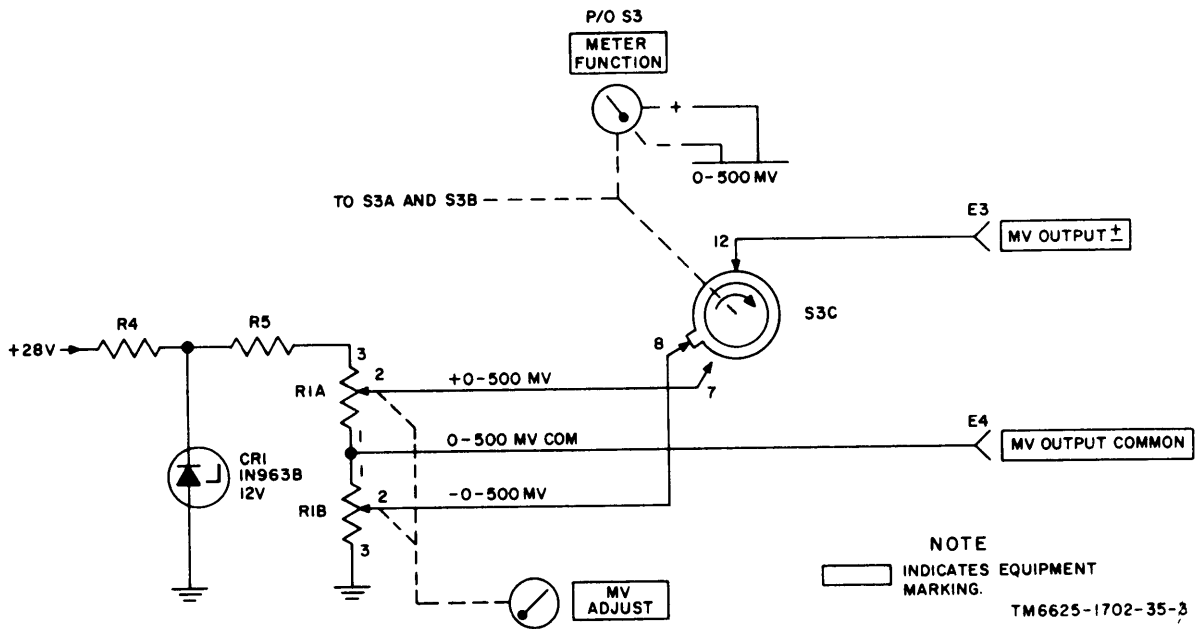
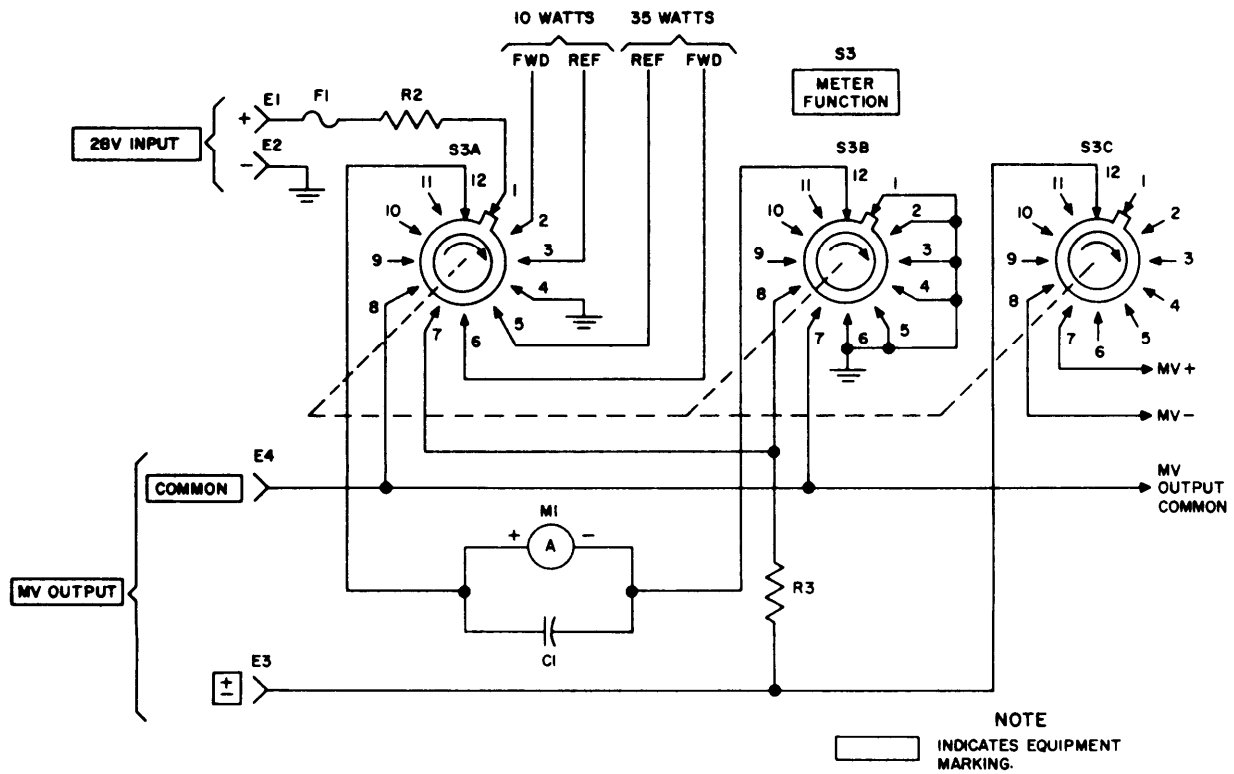

Figure 1-3. 0- to 500-millivolt power supply schematic diagram.

1-11. Meter Circuit
(fig. 1-4)

The meter circuit of the test set is controlled by METER FUNCTION switch S3. Switch wafers S3A and S3B control the meter circuit. In S3 switch position 1, the 28-volt source is measured with load resistor R2. In S3 switch positions 2 and 3, forward and reflected power measurements of as high as a 10-watt RF power source are taken using outputs and load-

ing of pins 1 and 2 of RF directional power sensor Z1. In S3 switch position 4, the metering circuit is turned off. In S3 switch positions 5 and 6, forward and reflected power measurements of as high as a 35-watt RF power source are taken using outputs and loading of pins 4 and 5 of RF directional power sensor Z1. In S3 switch positions 7 and 8, the 0- to 500-millivolt power source is measured with load resistor R3.



TM6625-1702-35-4

Figure 1-4. Meter circuit, schematic diagram.

1-12. Tune Indicator Circuit

(fig. 1-5)

When tuning of the antenna under test is activated, negative pulses are supplied by the antenna under test to the base of Q1 and Q1 biases off. When Q1 biases off, C2 starts to discharge. As the negative pulse at Q1 returns positive, Q1 conducts and C2 charges. If the time elapsed between pulses is too great, C2 will have charged and the process will start over again; however, if C2 is discharged and another pulse is received before C2 has

charged, C2 will discharge to a lower level. If this discharging process continues, C2 will discharge to a level where the voltage applied across CR4, CR3, and the base-emitter junction of Q2 will cause Q2 to bias off. When Q2 biases off, Q3 conducts and DS1 lights, indicating that tuning is in process. Under normal conditions with +28 volts dc applied and no input at pin K (coupler not connected) of the test set, DS1 will be lighted. In this manner DS1 also serves as a +28-volt de power indicator for the test set.

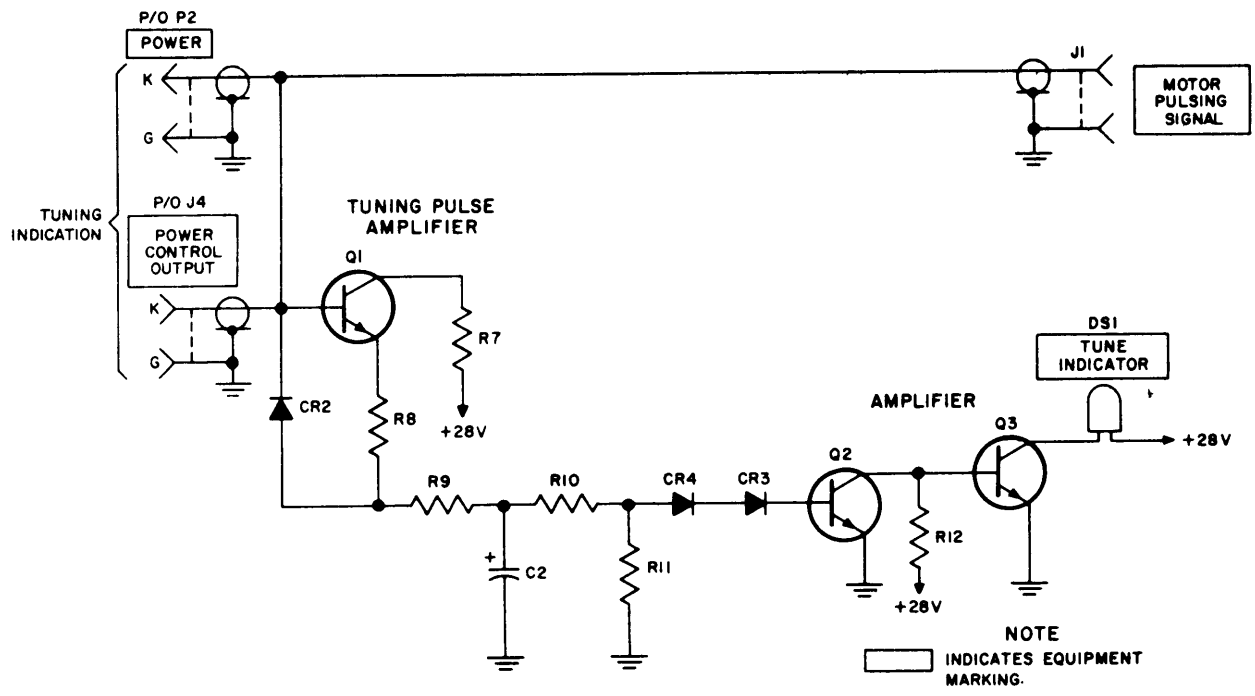

TM6625-1702-35-5

Figure 1-5. Tune indicator circuit, schematic diagram.

CHAPTER 2

TROUBLESHOOTING

Section I. GENERAL TROUBLESHOOTING TECHNIQUES

Warning: Be careful when working on the 115-volt ac line connections. DEATH or SERIOUS INJURY may result from contact with these terminals.

2-1. General Instructions

Troubleshooting at the direct support, general support, and depot maintenance categories includes all the techniques outlined for organizational maintenance and any special or additional techniques required to isolate a defective part. Paragraphs 2-4 through 2-7 describe intraunit (within the unit) localizing and isolating procedures to be used at the direct support maintenance category.

2-2. Organization of Troubleshooting Procedures

a. General. The first procedure in servicing the test set is to localize the fault. Localization means tracing the fault to a defective stage or circuit responsible for the abnormal condition. The second procedure is isolation which means finding the defective part or parts. Some defective parts, such as burned resistors and arching shorted transformers, can often be located by sight, smell, and hearing. Most defective parts, however, must be isolated by checking voltages and resistance.

b. Localization. Test set malfunctions are localized by using the troubleshooting chart in paragraph 2-5c. This chart lists common trouble symptoms and provides corrective measures. Since the chart cannot list all trouble symptoms that may appear, it should be used as a guide for analyzing symptoms that are not listed.

c. Isolation. Procedures for isolating trou-

bles in the test set to a particular component are listed in paragraph 2-7.

d. Techniques. In performing localization and isolation procedures, one or more of the techniques described below may be applied. Use the techniques only as indicated, and observe all cautions.

(1) *Voltage measurements.* This equipment is transistorized. When measuring voltages, use tape or sleeving (spaghetti) to insulate the entire test prod, except for the extreme tip. A momentary short circuit can ruin a transistor. Use Multimeter ME-26D/U.

(2) *Resistance measurements.* Resistance measurements are used to perform continuity checks as well as to measure the resistance of a circuit or component. Be careful when checking transistors.

(3) *Waveshapes.* Compare the waveshape obtained at an indicated point with that shown in figure 4-4.

(4) *Intermittent troubles.* In all the tests, the possibility of intermittent troubles should not be overlooked. If present, this type of trouble often may be made to appear by tapping or jarring the equipment. Make a visual inspection of the wiring and connections to the units of the test set. Minute cracks in the printed circuit board can cause intermittent operation. A magnifying glass is often helpful in locating defects in the printed circuit board.

(5) *Resistor and capacitor color code diagrams.* Color code diagrams for resistors and capacitors (figs. 5-1 and 5-2) are provided to aid maintenance personnel in determining

the value, voltage rating, and tolerance of resistors and capacitors.

2-3. Test Equipment Required

The chart in *c* below lists the test equipment and associated technical manuals required for troubleshooting the test set.

a. Make test equipment connections with care so that short circuits will not be caused by exposed test equipment connectors. Tape or sleeve (spaghetti) test prods or clips as necessary to leave as little exposed metal as needed to make contact to the test set.

b. Observe polarity; a negative ground is required on the 28-volt dc line.

c. The following test equipment is required:

<i>Nomenclature</i>	<i>Technical manual</i>	<i>Common name</i>
Multimeter ME-26B/U. ^a	TM 11-6625- 200-12	Multimeter
Oscilloscope AN/USM-140A. ^a	TM 11-6625- 535-15	Oscilloscope
Wattmeter AN/URM-120.	TM 11-6625- 446-15	Wattmeter
Radio Set AN/ARC-131.	TM 11-5820- 670-12	Fm transmitter
Dummy Load, Electrical DA-75/U.	-----	RF load
Antenna Coupler, 437S-1/1A.	-----	Antenna coupler

a

Or equivalent

d. The following additional equipment is required.

Equipment
Cable Assembly, Radiofrequency
CG-3375/U.
Power supply, 28-volts dc-----

National/NATO stock No.
6625-00-935-0332

Section II. TROUBLESHOOTING PROCEDURES

2-4. Bench Test Setup

Bench testing requires that a power supply and a Radio Set AN/ARC-131 or equivalent be connected to the test set. The 28-volt dc power supply must be connected for all tests. The AN/ARC-131 must be connected only in specific instances. Refer to figures 4-1 through 4-6 for test setups. Figures 2-1 through 2-3 provide parts location.

Caution: Do not attempt to remove or replace any components before reading the instructions in paragraph 3-1. Do not make resistance measurement with power applied to the test set. Do not make resistance measurements that would place the multimeter across the test set meter M1.

a. Power Supply Connections.

(1) The power supply should be a 28-volt power supply with an output current rating of 0 to 3 amperes. With the 28-volt power source cables, that are provided with the test set, connect the power supply to the 28V INPUT of the test set.

(2) Radio Set AN/ARC-131 or equivalent is capable of being tuned to 30 and 76 megahertz (MHz). With Cable Assembly, Radio Frequency CG-3375/U, connect the RF output of the fm transmitter to the RF INPUT of the test set.

b. Connect all other test equipment (antenna coupler, multimeter, wattmeter, oscilloscope, and RF load) to the test set as specified in the particular troubleshooting procedure.

2-5. Localizing Troubles

a. General. The troubleshooting chart (*b* below) provides tests to determine the section or stage of the test set that is causing the malfunction. After the trouble has been localized, follow the appropriate isolation procedure listed in paragraph 2-7 to locate the defective component. Refer to figure 2-1, 2-2, and 2-3 for location of parts, controls, and component of the test set.

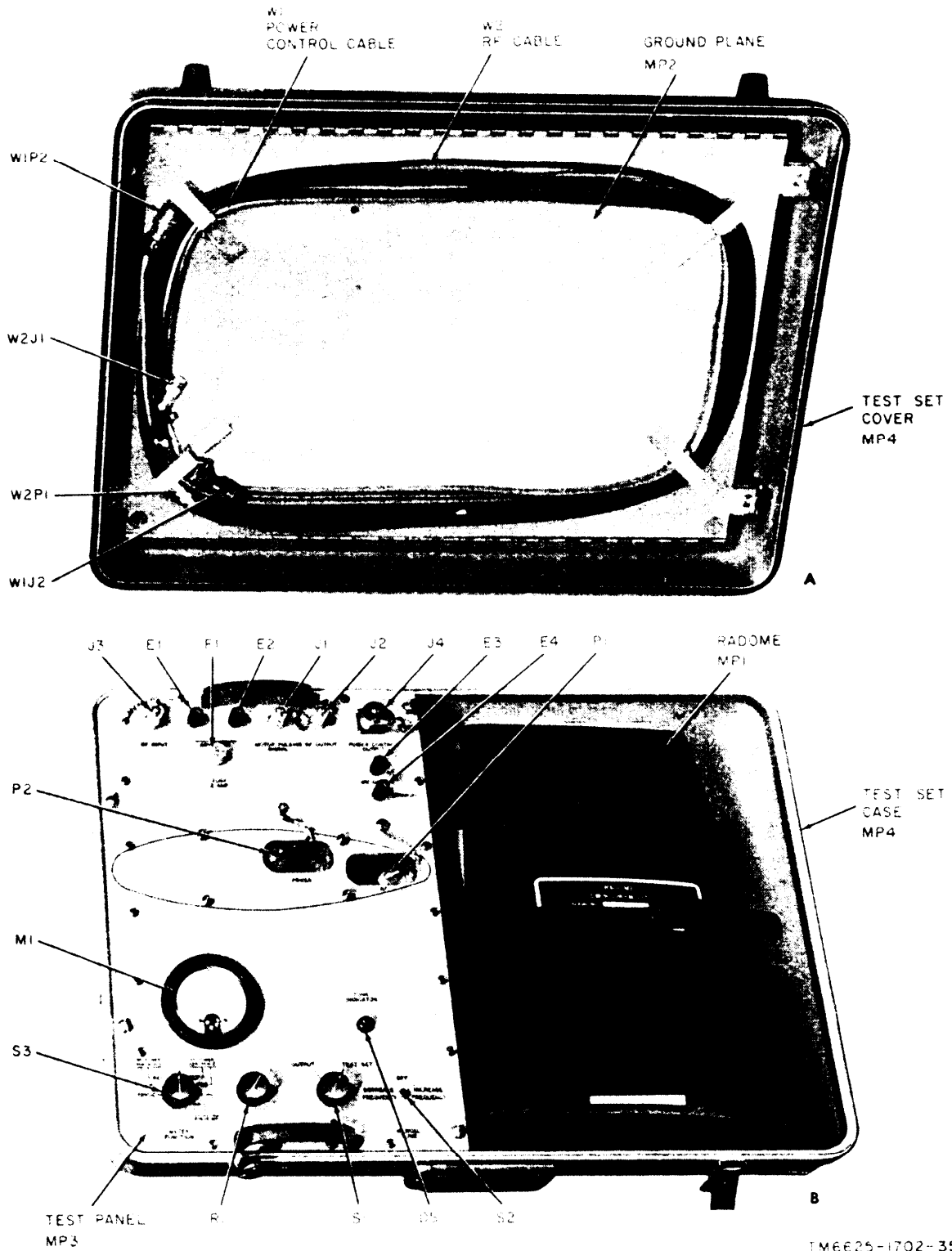
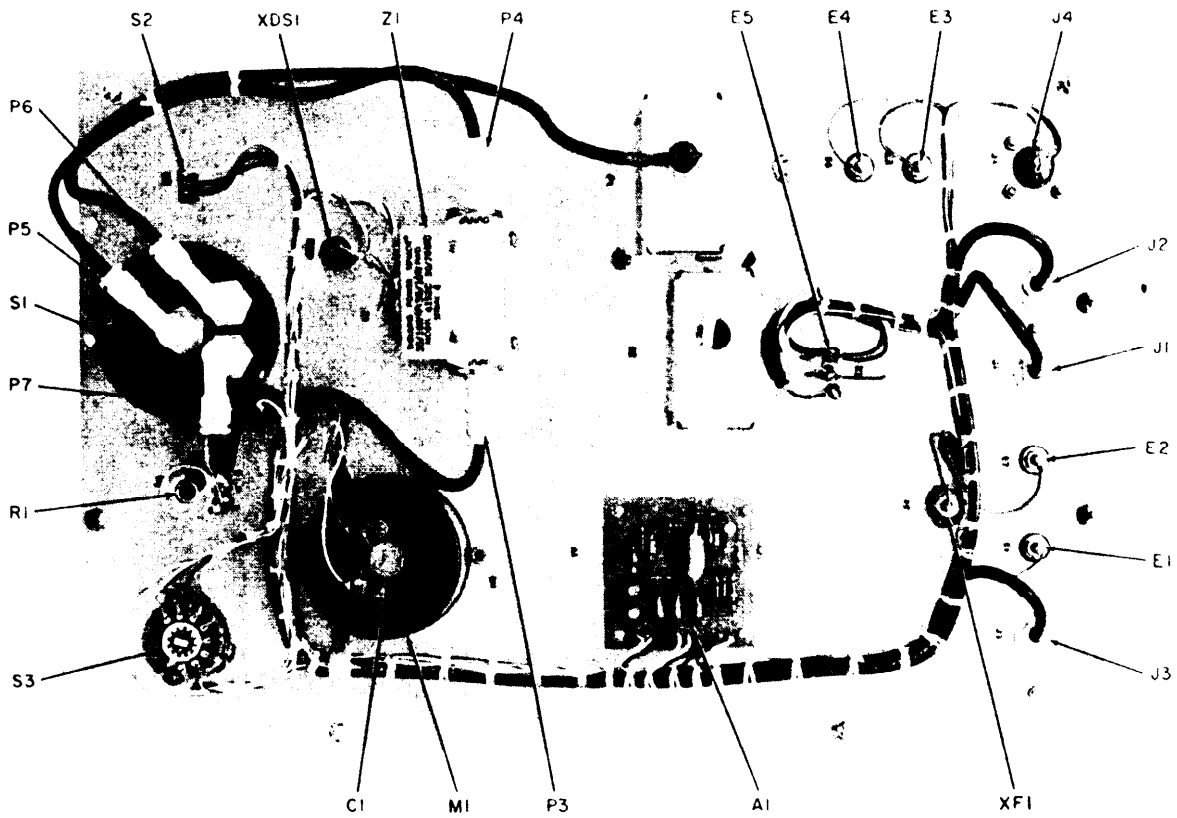

Figure 2-1. Test set front view, parts location.



TM6625-1702-35-7

Figure 2-2. Test panel rear view, parts location.

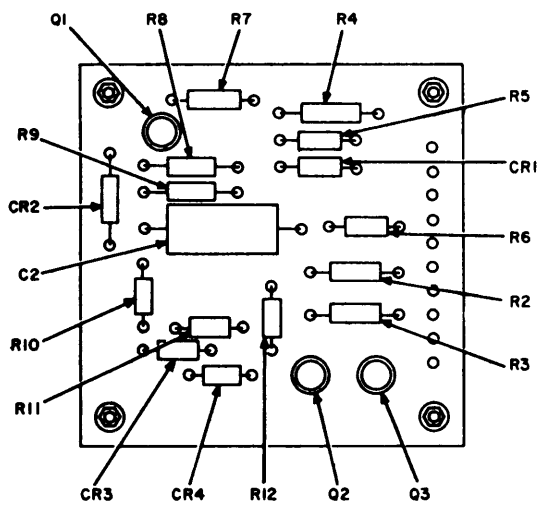

Figure 2-3. Circuit card assembly, parts location.

b. Troubleshooting Chart.

<i>Item No.</i>	<i>Test procedure</i>	<i>Symptom</i>	<i>Probable trouble</i>	<i>Correction</i>
1	Dc meter scale test (para 4-5).	a. Meter indication of 28-volt dc input high.	a. R2 or M1 defective ----	a. Replace defective component.
		b. Meter indication of 28-volt dc input low.	b. R2, C1, M1, or S3 defective or there is a short in the associated circuits.	b. Perform resistance and continuity checks (para 2-7b) to locate the defect. Replace defective component.
		c. Meter indication zero ---	c. F1, R2, M1, or S3 defective or there is an open circuit in the 28-volt dc line.	c. Perform resistance and continuity checks to locate the defect. Replace defective component.
2	Millivolt source test (para 4-6).	a. Voltage at MV OUTPUT terminals very unstable.	a. CR1 defective -----	a. Replace CR1.
		b. MV OUTPUT voltage zero.	b. R4, R5, R1, or CR1 defective.	b. Perform resistance checks to locate defective components. Replace defective component.
		c. MV OUTPUT voltage correct but meter indication is excessively high or low.	c. C1 or M1 defective ____	c. Replace defective component.
3	TUNE INDICATOR function test (para 4-7).	a. TUNE INDICATOR does not light.	a. DS1, Q3, Q2, or R12 defective.	a. Check TUNE INDICATOR DS1. Check resistance of R12. Perform voltage and resistance measurements (para 2-7c) on Q3 and Q2. Replace defective component.
		b. TUNE INDICATOR does not extinguish when coupler is connected and MV ADJUST control is fully counterclockwise.	b. CR2, CR3, CR4, Q2, Q3, R9, R10, R11, R12, or C2 defective.	b. Perform resistance checks and voltage and resistance measurements as required to isolate defective component. Replace defective component.
		c. TUNE INDICATOR does not illuminate brightly.	c. CR2, C2, Q2 or Q3 defective.	c. Perform voltage and resistance measurements as required to isolate malfunction. Replace defective component.
		d. Repetition rate too slow (greater than 20 ms) when TUNE INDICATOR reaches full brilliance.	d. Q1 defective -----	d. Replace Q1.
4	Coupler test (para 4-8).	a. Coupler does not cycle __	a. Z1, S1, or associated connectors or wiring defective.	a. Perform continuity checks on wiring, connectors, and S1. Repair or replace as required. If no defects are found in S1 or the associated wiring, replace Z1.

b. TUNE INDICATOR does not extinguish and coupler does not stop tuning when FR is removed.

b. Wiring defective ----- b. Perform continuity checks to locate defect, and replace or repair as required.

5 RF wattmeter test (para 4-9). Power indications incorrect.

Wiring to Z1 or to S3 defective Z1 defective. Perform continuity checks to locate defects in wiring. Repair or replace as required. If no defects are located in wiring, replace Z1.

2-6. Waveform Analysis

a. The tuning signal from the antenna coupler may be monitored at MOTOR PULSING SIGNAL jack J1 of the test set with an oscilloscope. The normal waveform obtained at the test jack is shown in figure 4-4,

b. Since the antenna coupler used in testing the test set is known to be working properly, a departure from the normal waveform indicates that trouble exists in the test set. Check all wiring between the point at which the waveform is observed and the antenna coupler.

2-7. Isolating Troubles

a. *General.* Once a trouble has been localized to a functional circuit in the test set, it may be necessary to perform further tests to isolate the trouble to a particular component. When a trouble has been localized to a functional circuit, review the principles of operation of that circuit (paras 1-8 through 1-12). Then perform resistance and continuity checks (b below) and voltage resistance measurements (c below) as required.

Caution: Do not make resistance and continuity checks with power applied to the test set. Do not make any measurements that would place the multimeter across test set meter M1.

b. *Resistance and Continuity Checks.* Whenever required, perform resistance and continuity checks on resistors, capacitors, and wiring with a multimeter.

c. *Voltage and Resistance Measurements.* When required, voltage and resistance measurements are taken at the emitters, bases, and collectors of Q1, Q2, and Q3. The normal meas-

urements are presented in the chart in (2) below. Use these measurements and the schematic diagram (fig. 5-3) to isolate troubles.

Caution: When measuring voltages, use tape or sleeving (spaghetti) to insulate the entire test prod, except for the extreme tip. A momentary short circuit can ruin a transistor.

(1) The voltage readings will always be obtained as given in (a) through (d) below.

(a) Make voltage measurements using Multimeter ME-26B/U or equivalent.

(b) Make all voltage measurements with respect to chassis ground.

(c) Make all voltage measurements with dc power (28 volts) applied. Do not connect any other test equipment such as the fm transmitter or the antenna coupler.

(d) Make all voltage measurements with the MANUAL TUNE switch and the METER FUNCTION switch set to OFF.

(2) Resistance measurements are made with power disconnected from the test set. Use a multimeter, and make all resistance measurements with respect to chassis ground.

Transistor		DC voltage	Resistance
Q1	- E	12.9	31.6K
	- B	13.0	26K
	- C	13.2	25.9K
Q2	- E	0	0
	- B	0.2	15K
	- C	0.2	19.9K
Q3	- E	0	0
	- B	0.2	19.9K
	- C	28	1 meg.

CHAPTER 3

REPAIRS AND ALIGNMENT

3-1. General Parts Replacement Techniques

The general precautions in *a* through *c* below should be observed when replacing parts in this equipment. See figures 2-1 and 2-2 for location of test panel parts.

a. When soldering or unsoldering components, solder quickly to allow as little heat conduction as possible. Whenever wiring permits, use a heat skin (such as a pair of long-nosed pliers) between the solder joint and the component. Use approximately the same length and dress of leads as used originally.

b. Use a pencil-type iron with a 25-watt maximum capacity. If the iron must be used with alternating current, use an isolation transformer between the iron and the line. Check soldering irons for short circuits to the iron tip before using.

c. Whenever an electrical part such as a resistor or diode is to be removed, note the exact position of the component before removing it. Replace the component in the same position.

3-2. Removal of Test Panel from Test Set Case

a. Loosen the four turn lock fasteners at the perimeter of the test panel.

b. Lift the test panel from the test set case.

3-3. Removal of Test Panel Dust Cover

a. Place the test panel (removed from case) face up.

b. Remove the 18 Phillip's-head screws from the perimeter of the test panel.

c. Carefully lift the test panel from the dust cover.

3-4. Removal of RF Directional Power Sensor Z1

a. Remove the four mounting screws from the RF directional power sensor.

b. Disconnect the input and output connectors.

c. With a 25-watt, pencil-type soldering iron, remove the four dc output leads.

3-5. Removal of Component Board A1

a. Remove the four hexagonal nuts and washers from the support posts that secure the component board to the test panel.

b. Carefully fold the component board over the cabling.

c. With a 25-watt, pencil-type soldering iron, carefully remove the leads from the component board. Be sure to clearly label each lead to insure proper connection when they are replaced.

3-6. Removal of METER FUNCTION Switch S3

a. Remove all leads from switch S3. Be sure to clearly label the leads to insure proper replacement.

b. Remove the METER FUNCTION knob from the test panel of the test set.

c. Remove the hexagonal nut and lockwasher that secure switch S3 to the test panel.

3-7. Removal of RF SELECT Switch S1

a. Remove the three BNC connectors from switch S1. Be sure to clearly label the leads to insure proper replacement.

b. Remove the RF SELECT knob from the test panel of the test set.

c. Remove the nut, lockwasher, and escutcheon plate that secure switch S1 to the test panel.

3-8. Replacement of RF SELECT Switch S1

a. Properly connect all leads to switch S1.

b. Replace the RF SELECT switch in the test panel.

c. Replace the escutcheon plate, lockwasher, and nut.

d. Replace the RF SELECT switch knob.

3-9. Replacement of METER FUNCTION

Switch S3

a. Properly connect all leads to switch S3.

b. Replace the METER FUNCTION switch in the test panel.

c. Replace the lockwasher and hexnut.

d. Replace the METER FUNCTION knob.

3-10. Replacement of Component Board A1

a. With a 25-watt, pencil-type soldering iron, connect all leads to their proper terminals.

b. Align the holes in the circuit board over the support posts, and replace the four washers and four hexagonal nuts.

3-11. Replacement of Dust Cover

Note. Before replacing the dust cover, check to see that all connections required are properly made and that all connectors are secure.

a. Place the dust cover, open end up, on a flat surface.

b. Carefully slide the test panel into place.

c. Replace the 18 Phillip's-head screws.

3-12. Replacement of Test Panel

a. Carefully place the test panel in the test set case.

b. Secure the test panel with the four turn-lock fasteners.

3-13. Equipment Adjustments

a. Disconnect all power from the test set.

b. Mechanically align the M1 meter indication to zero with the adjustment screw on the face of the meter.

3-14. Alignment

Alignment procedures are not applicable to the test set as covered in this manual.

CHAPTER 4

GENERAL SUPPORT TESTING PROCEDURES

4-1. General

a. Testing procedures are prepared for use by general support maintenance shops responsible for general support maintenance of electronic equipment to determine the acceptability of repaired electronic equipment. These procedures set forth specific requirements that repaired electronic equipment *must* meet before it is returned to the using organization. These procedures may also be used as a guide for testing equipment which has been repaired at direct support if the proper tools and test equipment are available. A summary of the performance standards is given in paragraph 4-10.

b. Comply with the instructions preceding the body of each chart before proceeding to the chart. Perform each test in sequence. Do not vary the sequence. For each step, perform all the actions required in the *Control settings* columns; then perform each specific test procedure, and verify it against its performance standard.

4-2. Test Equipment, Tools, and Materials

All test equipment, tools, materials, and other equipment required to perform the testing procedures given in this section are listed in the chart below and are authorized under TA 11-17 and TA 11-100 (11-17).

Nomenclature	National/NATO stock No.	Technical Manual
Multimeter ME-26B/U. ¹	6625-00-646-9409	TM 11-6625-200-12
Oscilloscope AN/USM-140A ²	6625-00-987-6603	TM 11-6625-535-15
Wattmeter AN/URM-120.	6625-00-813-8430	TM 11-6625-446-15
Dummy Load, Electrical DA-75/U.	6625-00-177-1639	
Radio Set AN/ARC-131.	5831-00-937-4686	TM 11-5820-670-20
Antenna Coupler 437S-1/1A.		
Cable Assembly, Radio Frequency CG3375/U.	6625-00-935-0332	
Tool Kit, Electronic Equipment TK-100/G.	5180-00-605-0079	
Tool Kit, Operations Central TK-101/GSQ.	5180-00-064-5178	
Tool Kit, Electronic Equipment TK-105/G.	5180-00-610-8177	

¹Equivalent ME-262D/U

²Or Equivalent AN/USM-281A

4-3. Test Facilities

Primary power requirements are for 27.5 ±0.5 volts dc with a maximum capacity of 2 amperes. For the operation of certain test equipment, 120 ±12 volts, 60-Hertz (Hz), single-phase power is also required. Temperature, humidity, and atmospheric pressure are not critical.

4-4. Physical Tests and Inspection

(fig 2-1)

a. *Test Equipment and Materials.* No test equipment or materials are required.

b. *Test Connections and Conditions.* Remove the test panel from the test set case, and remove the dust cover from the test panel.

c. Procedure.

Step No.	Test equipment	Control settings	Equipment under test	Test procedures	Performance standard
1	N/A	N/A		<p>a. Inspect case and chassis for damage, missing parts, and condition of paint.</p> <p><i>Note.</i> Touchup painting is recommended instead of refinishing whenever practical; screw heads, binding posts, receptacles, and other plated parts will not be painted or polished with abrasive.</p> <p>b. Inspect all controls and mechanical assemblies for loose or missing screws, belts, and nuts.</p> <p>c. Inspect all connectors, sockets, and receptacles, and fuseholder and meter for looseness, damage, or missing parts.</p> <p>d. Rotate all panel controls throughout their limits of travel.</p>	<p>a. No damage evident or parts missing. External surfaces intended to be painted do not show bare metal. Panel lettering is legible.</p> <p>b. Screws, bolts, and nuts are tight with none missing.</p> <p>c. No loose or missing parts; No damage evident.</p> <p>d. Controls rotate freely without binding or excessive looseness.</p>

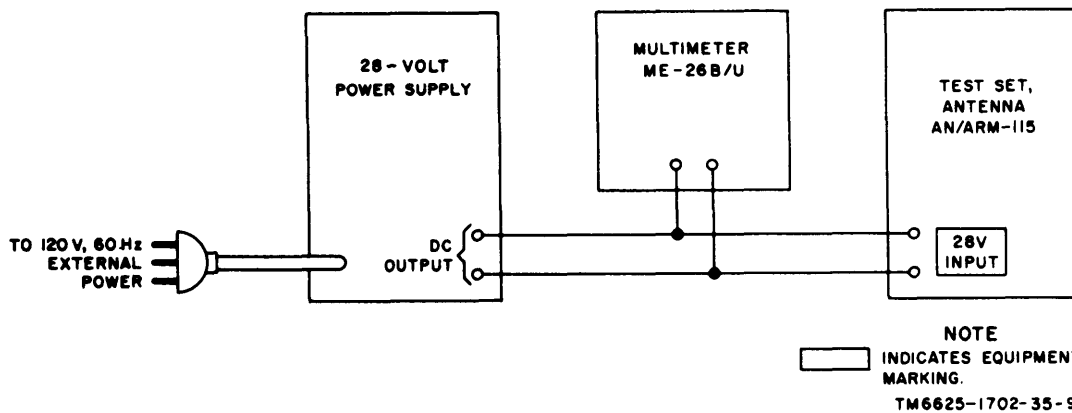

Figure 4-1. Dc meter scale test, test setup.

4-5. Dc Meter Scale Test

(fig. 4-1)

a. Test Equipment and Materials.

- (1) Power supply, 28-volt dc.
- (2) Multimeter ME-26B/U.

b. Test Connections and Conditions. Connect the test equipment as shown in figure 4-1.

c. Procedures.

Step No.	Test equipment	Control Settings	Equipment under test	Test procedure.	Performance standard
1	a. Set multimeter to 30-volt dc scale.	a. None	a. None	a. None	a. None
	b. Turn on power supply and allow time for warm up.	b. Set METER FUNCTION switch to 28VDC.	b. Adjust power supply to obtain a 27.5-volt indication on multimeter.	b. Test set meter indicates 27.5 ± 1.3 volts dc.	

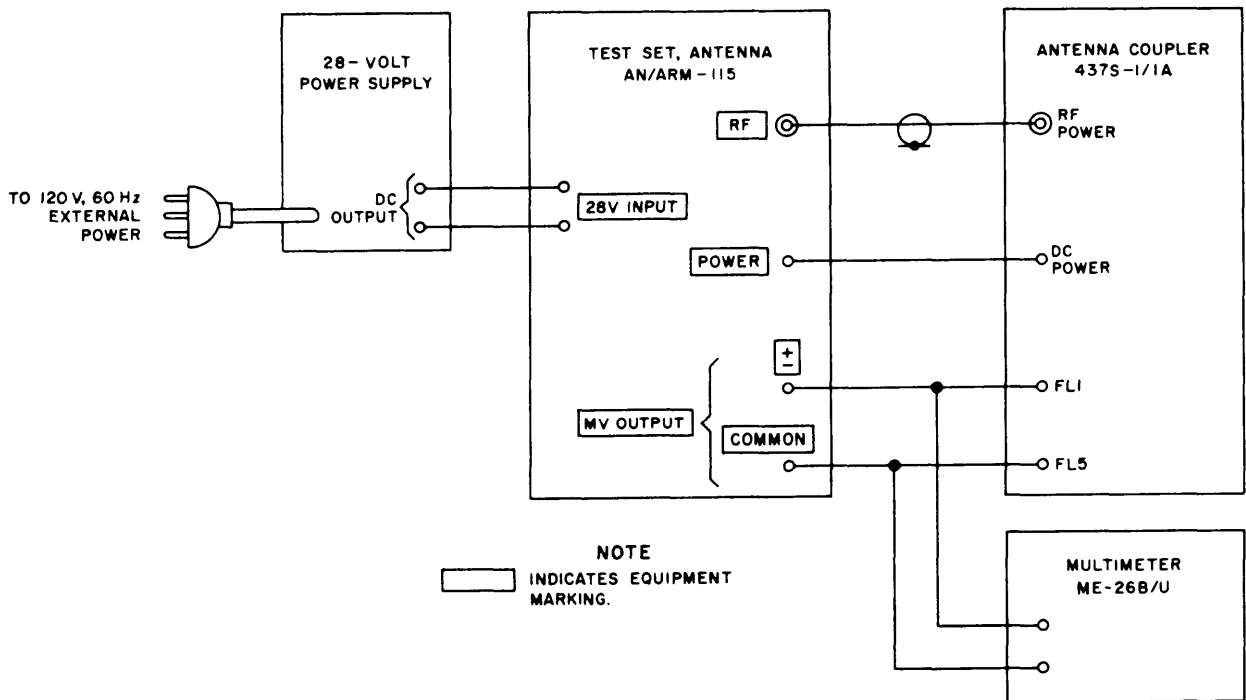

TM6625-1702-35-10

Figure 4-2. Millivolt source test, test setup.

4-6. Millivolt Source Test

(fig. 4-2)

a. Test Equipment and Materials.

- (1) Power supply, 28-volt dc.
- (2) Antenna Coupler, 437S-1/1A.
- (3) Multimeter ME-26B/U.

b. Test Connections and Conditions. Connect the test equipment as shown in figure 4-2.

c. Procedures.

Control settings

Step No.	Test equipment	Equipment under test	Test procedures	Performance standard
1 a.	Turn on power supply, and allow time for warm up.	Set METER FUNCTION switch to 28VDC.	Adjust power supply to obtain 27.5-volt indication on power supply meter.	Test set meter indicates 27.5 ± 1.3 volts dc.
b.	Set multimeter to 1-volt dc range.	Set METER FUNCTION switch to 0-500 MV.	Adjust MV ADJUST for 250-mv indication on multimeter.	Test set meter indicates 250 ± 12 mv.
2	Set multimeter to -0.6-volt dc range.	Set METER FUNCTION switch to - 0-500 MV.	Adjust MV ADJUST for 250-mv indication on multimeter.	Test set meter indicates -250 ± 12 .

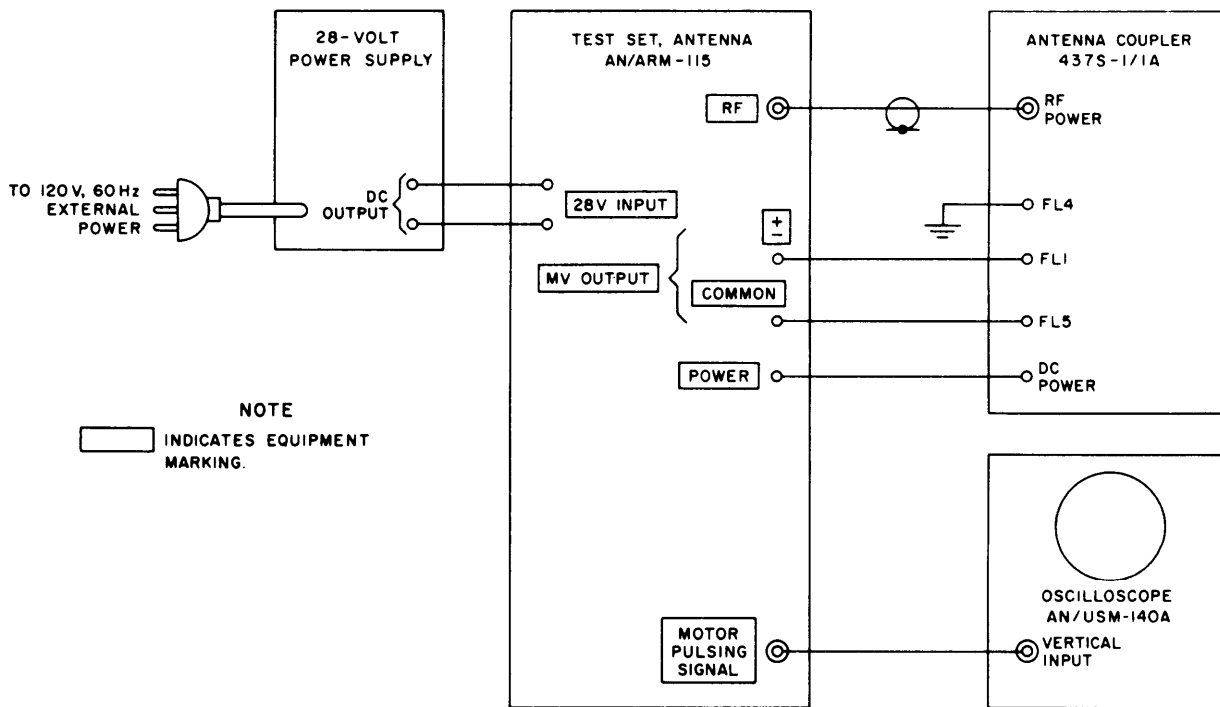

TM6625-1702-35-11

Figure 4-3. TUNE INDICATOR function test, test setup.

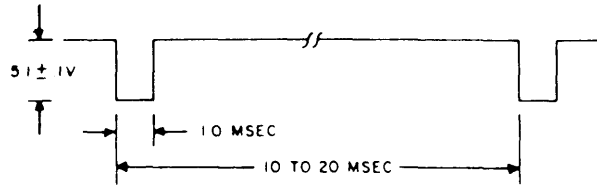

TM6625-1702-35-12

Figure 4-4. TUNE INDICATOR function test, waveform.

4-7. TUNE INDICATOR Function Test

(fig. 4-3)

a. Test Equipment and Materials.

- (1) Power supply, 28-volt dc.
- (2) Oscilloscope AN/USM-140A.
- (3) Antenna Coupler, 437S-1/1A.

b. Test Connections and Conditions. Connect the test equipment as shown in figure 4-3.

c. Procedure.

Step No.	Test equipment	Control settings Equipment under test	Test procedures	Performance standard
1 a.	Turn on power supply and allow time for warmup.	a. Set METER FUNCTION switch to 28 VDC.	a. Adjust power supply to obtain 27.5-volt indication on power supply meter.	a. Test set meter indicates 27.5 ± 1.3 volts dc.
b.	Turn on oscilloscope and allow time for warmup.	b. Rotate MV ADJUST fully counterclockwise.	b. Connect MV OUTPUT terminals to FL1 and FL5 of antenna coupler. Connect FL4 to ground (fig. 4-3).	b. None.

NOTE

If antenna coupler 4375-1 is used, perform step 1c and skip 1d; otherwise, skip step 1c.

c. None	c. Turn off power. S2 to "OFF."	c. Measure resistance from J4-A to Gnd.	c. Should read open circuit.
	S2 to "Decrease Freq."	Measure resistance from P2-A to Gnd and J4-A to Gnd.	Should read <1 ohm.
	S2 to "OFF."	Measure resistance from J4-B to Gnd.	Should read open circuit.
	S2 to "Increase Freq."	Measure resistance from P2-B to Gnd and from J4-B to Gnd.	Should read <1 ohm.
	Turn on power	None	None
d. None	d. Momentarily set MANUAL TUNE switch S2 to either INCREASE FREQUENCY or DECREASE FREQUENCY.	d. Monitor motor pulsing signal on oscilloscope.	d. Oscilloscope waveform is similar to that in figure 4-4.
e. None	e. None	e. Increase repetition rate of motor pulsing signal by rotating MV ADJUST until TUNE INDICATOR illuminates brightly.	e. Repetition period of motor pulsing signal is 15 ± 5ms.

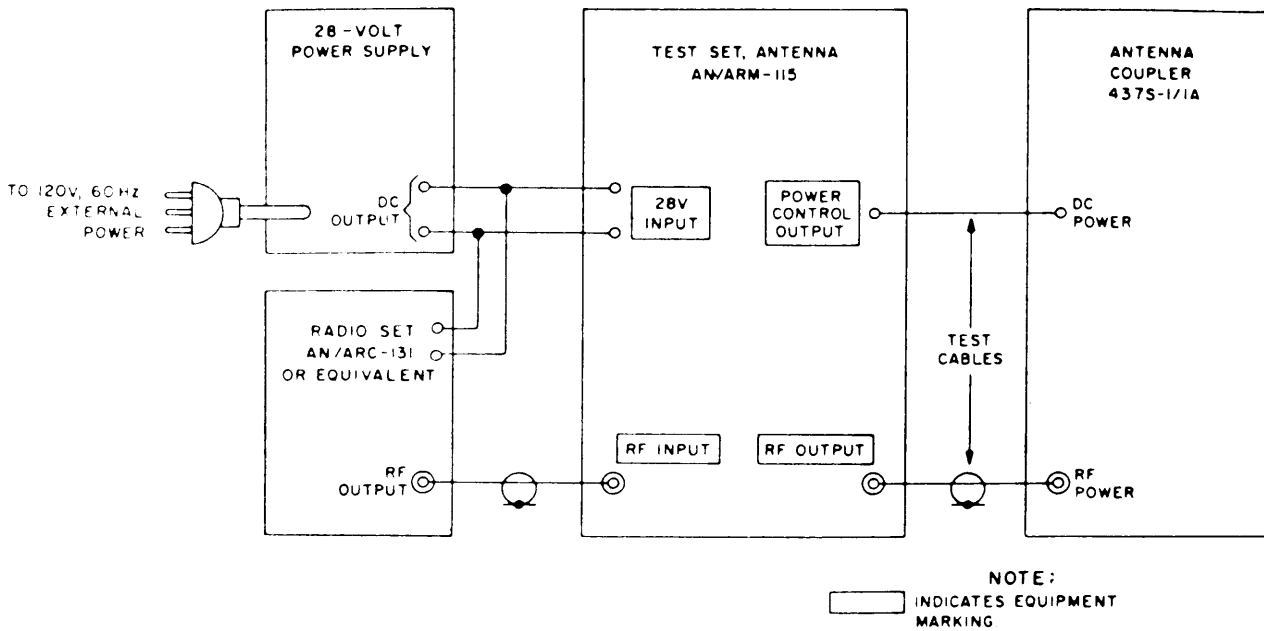

Figure 4-5. Coupler test, test setup.

TM6625-1702-35-13

4-8. Coupler Test

(fig. 4-5)

a. Test Equipment and Materials.

- (1) Power supply, 28-volt dc.
- (2) Radio Set AN/ARC-131 or equivalent.
- (3) Antenna Coupler, 437S-1/1A.

b. Test Connections and Conditions. Connect the test equipment as shown in figure 4-5. Use the test leads supplied. Mount the antenna coupler on the ground plane supplied.

c. Procedure.

Step No.	Test equipment	Control settings Equipment under test	Test procedures	Performance standard
1 a.	Turn on power supply and fm transmitter. Allow time for warm up.	a. Set RF SELECT switch to OUTPUT. Set METER FUNCTION switch to 28VDC. Set MANUAL TUNE switch to OFF.	a. Adjust power supply to obtain a 27.5-volt dc indication on power supply meter.	a. Test set meter indicates 27.5 ±1.3 volts dc.
b.	None	b. None	b. Apply RF power to the test panel, and check for proper cyclic action of the coupler.	b. TUNE INDICATOR should be lighted.
c.	None	c. None	c. When coupler has been cycled to minimum capacity and is moving toward maximum capacity, remove RF power from test set.	c. TUNE INDICATOR extinguishes and coupler stops.

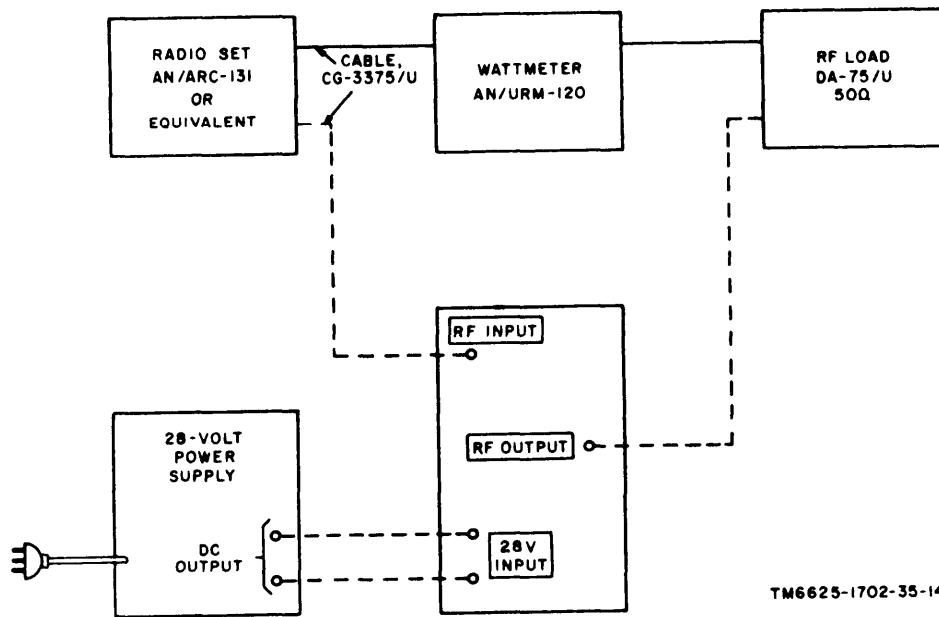

TM6625-1702-35-14

Figure 4-8. RF wattmeter test setup.

4-9. RF Wattmeter Test

(fig. 4-6)

a. Test Equipment and Materials

- (1) Power supply, 28-volt.
- (2) Radio Set AN/ARC-131.
- (3) Dummy Load, Electrical DA-75/U.
- (4) Wattmeter AN/URM-120.
- (5) Cable Assembly, Radio Frequency CG-3375/U.

b. Test Connections and Conditions.

- (1) For step No. 1, connect the test equipment as shown by solid lines in figure 4-6.
- (2) For step No. 2, connect the test equipment as shown by broken lines in figure 4-6.

c. Procedure.

Step No.	Test equipment	Control settings Equipment under test	Test procedure	Performance standard
1	a. Apply power to fm transmitter, and allow time for warm up.	a. None	a. Adjust fm transmitter frequency to 30 MHz. Measure forward rf power with AN/URM-120 and record reading.	a. None.
	b. None	b. None	b. Measure reflected RF power with AN/URM-120, and record reading.	b. None.
	c. None	c. None	c. Adjust fm transmitter frequency to 76 MHz. Measure forward RF power with AN/URM-120, and record reading.	c. None.

Step No.	Control settings Test equipment	Equipment under test	Test procedures	Performance standard
	d. None -----	d. None -----	d. Measure reflected RF power with AN/URM-120, and record reading.	d. None.
	e. None	e. None	e. Disconnect AN/URM120 and connect equipment as shown by broken lines in figure 4-6.	e. None
2 a.	Turn on power supply, and allow time for warm up.	Set METER FUNCTION switch to 28 VDC.	Adjust power supply to obtain a 27.5-volt indication on power supply meter.	a. Test set meter indicates 27.5 ±1.3 volts dc.
b.	Turn on fm transmitter, and allow warm up time.	Set RF SELECT switch to OUTPUT.	Adjust fm transmitter frequency to 30 MHz.	b. None.
c.	None -----	c. IMPORTANT: If power measured in step 1a above exceeds 10-watts, set METER FUNCTION switch to RF POWER 35W SCALE-FWD.	c. Measure forward RF power on test set meter, and recording reading.	c. Test set meter indicates same reading in watts as recorded in step 1a above, ±10%.
d.	None -----	d. Set METER FUNCTION switch to RF POWER 10W SCALE-REF.	d. Measure reflected RF power on test set meter, and record reading.	d. Test set meter indicates same reading in watts as recorded in step 1b above, ±10%.
e.	None -----	e. None -----	e. Adjust fm transmitter frequency to 76 MHz.	e. None.
f.	None -----	f. Set METER FUNCTION switch to RF POWER 35W SCALE-FWD.	f. Measure forward RF power on test set meter, and record reading.	f. Test set meter indicates same reading in watts as recorded in step 1c above, ±10%.
g.	None -----	g. Set METER FUNCTION switch to RF POWER 10W SCALE-REF.	g. Measure reflected RF power on test set meter, and record reading.	g. Test set meter indicates same reading in watts as recorded in step 1d above, ±10%.

4-10. Antenna Element Test

(fig. 4-5)

a. Test Equipment and Materials.

- (1) Power supply, 28 volt dc.
- (2) Radio Set AN/ARC-131, or equivalent.
- (3) Antenna Coupler, 437S-1/1A.

c. Procedures.

(4) Ground plane.

(5) Test radome.

b. Test Connections and Conditions. Connect the test equipment as shown in figure 4-5. Use the test leads supplied. Insert the antenna coupler into the test radome and mount on the ground plane.

Step No	Control settings		Test procedures	Performance standard
	Test equipment	Equipment under test		
1	Turn on power supply and fm transmitter. Allow time for warm-up.	Set RF SELECT switch to OUTPUT. Set METER FUNCTION switch to 28 VDC. Set MANUAL TUNE switch to OFF.	Adjust power supply to obtain a 27.5 volt dc indication on test set meter.	None.
2	None	Set MANUAL TUNE switch alternately to INCREASE FREQUENCY and DECREASE FREQUENCY.	Apply RF power to the test panel and observe cyclic action of the antenna coupler.	If antenna coupler is type 437S-1, antenna coupler remains inactive. If antenna coupler is type 437S-1A, antenna coupler operates.

4-11. Test Data Summary

The chart below lists the performance standards for each individual performance test. Use this chart to compare the values obtained during testing with the performance standards of the test set.

<i>Performance test</i>	<i>Performance standard</i>
a. Dc meter scale test (para 4-5).	a. Input voltage 27.5 ±1.3 volts dc.
b. Millivolt source test (para 4-6).	b. Millivolt output: +250 ±12 mv; -250 ±12 mv.
c. TUNE INDICATOR function test (para 4-7).	c. Repetition rate for indicator full brilliance : 15 ±5 ms.

<i>Performance test</i>	<i>Performance standard</i>
d. Coupler test (para 4-8).	d. Coupler stops cycling when RF power is removed.
e. RF wattmeter test (para 4-9).	e. With fm transmitter frequency set at 30 MHz or 76 MHz, forward and re-reflected RF power readings on AN/ARM-115 agree with readings recorded on AN/URM-120 ±10%.
f. Antenna element test.	f. Coupler 437S-1 remains inactive. Coupler 437S-1A operates.

CHAPTER 5

DEPOT OVERHAUL STANDARDS

5-1. Applicability of Depot Overhaul Standards

The tests outlined in this chapter are designed to measure the performance capability of a repaired equipment. Equipment that is to be returned to stock should meet the standards given in these tests.

5-2. Applicable References

a. Repair Standards. Applicable procedures of the depots performing these tests and the general standards for repaired electronic equipment given in TB SIG 355-1, TB SIG 355-2, and TB SIG 355-3 form a part of the requirements for testing this equipment.

b. Technical Publication. The only other technical publication applicable to the equipment to be tested is TM 11-6625-1702-12.

c. Modification Work Orders. Perform all modification work orders (MWO's) applicable to this equipment before making the tests

specified. DA Pam 310-7 lists all available MWO's.

5-3. Test Procedures

a. The test equipment and power required for depot inspection standards are the same as indicated in paragraphs 4-2 and 4-3.

b. The operational tests for depot inspection standards are the same as the tests given in paragraphs 4-5 through 4-9 and listed in the chart below. Perform the tests in the order in which they are given, and check to see that the results meet the minimum standard indicated for each test.

<i>Tests</i>	<i>Paragraph</i>
Dc meter scale test -----	4-5
Millivolt source test _____	4-6
TUNE INDICATOR function test _____	4-7
Coupler test -----	4-8
RF wattmeter test -----	4-9

COLOR CODE MARKING FOR MILITARY STANDARD RESISTORS

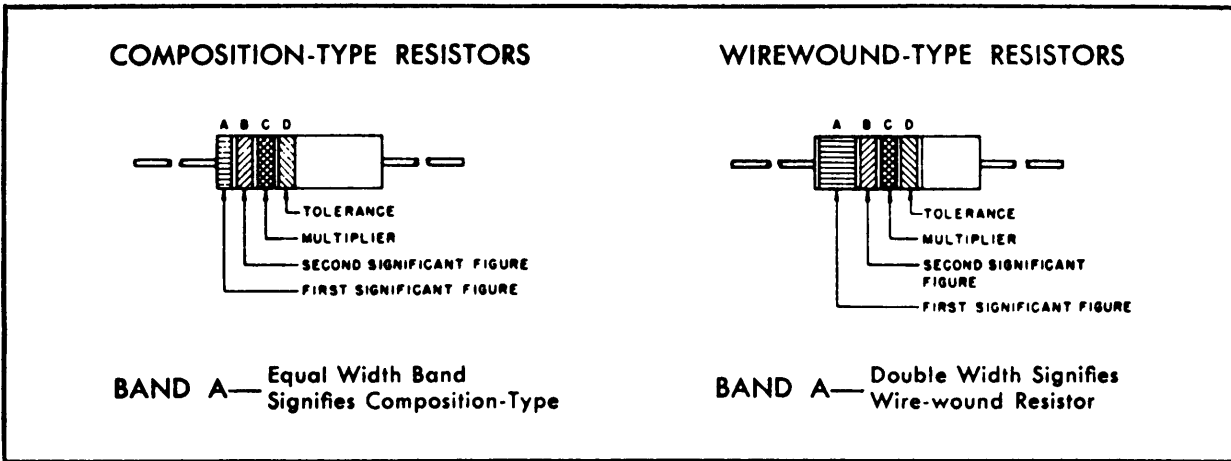

COLOR CODE TABLE

BAND A		BAND B		BAND C		BAND D*	
COLOR	FIRST SIGNIFICANT FIGURE	COLOR	SECOND SIGNIFICANT FIGURE	COLOR	MULTIPLIER	COLOR	RESISTANCE TOLERANCE (PERCENT)
BLACK	0	BLACK	0	BLACK	1		
BROWN	1	BROWN	1	BROWN	10		
RED	2	RED	2	RED	100		
ORANGE	3	ORANGE	3	ORANGE	1,000		
YELLOW	4	YELLOW	4	YELLOW	10,000	SILVER	± 10
GREEN	5	GREEN	5	GREEN	100,000	GOLD	± 5
BLUE	6	BLUE	6	BLUE	1,000,000		
PURPLE (VIOLET)	7	PURPLE (VIOLET)	7				
GRAY	8	GRAY	8	SILVER	0.01		
WHITE	9	WHITE	9	GOLD	0.1		

EXAMPLES OF COLOR CODING

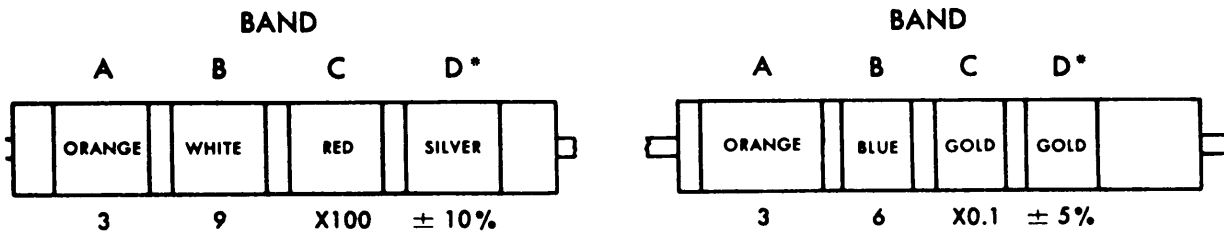

NOMINAL RESISTANCE 3,900 Ohms
RESISTANCE TOLERANCE ± 10 percent

NOMINAL RESISTANCE 3.6 Ohms
RESISTANCE TOLERANCE ± 5 percent

STD-R2

*If Band D is omitted, the resistor tolerance is ± 20%, and the resistor is not Mil-Std.

Figure 5-1. Color code marking for MIL-STD resistors.

APPENDIX A

REFERENCES

Following is a list of applicable references available to direct support, general support and depot maintenance personnel of Test Set, Antenna AN/ARM-115.

DA Pam 310-4	Index of Technical Manuals, Technical Bulletins, Supply Manuals (types 7, 8, and 9), Supply Bulletins, and Lubrication Orders
DA Pam 310-7	U.S. Army Equipment Index of Modification Work Orders
TA 11-17	Signal Field Maintenance Shops
TA 11-100 (11-17)	Allowances of Signal Corps Expendable Supplies for Signal Field Maintenance Shops
TB SIG 355-1	Depot Inspection Standard for Repaired Signal Equipment
TB SIG 355-2	Depot Inspection Standard for Refinishing Repaired Signal Equipment
TB SIG 355-3	Depot Inspection Standard for Moisture and Fungus Resistant Treatment
TB SIG 364	Field Instructions for Painting and Preserving Electronics Command Equipment
TM 11-5820-670-12	Organizational Maintenance Manual: Radio Set AN/ARC-131
TM 11-6625-200-12	Organizational Maintenance Manual: Multimeters ME-26A/U, ME-26B/U, ME-26C/U, and ME-26D/U
TM 11-6625-446-15	Operator, Organizational, Field, and Depot Maintenance Manual: Wattmeter AN/URM-120
TM 11-6625-535-15	Organizational, DS, GS, and Depot Maintenance Manual: Oscilloscope AN/USM-140A
TM 11-6625-1702-12	Operator and Organizational Maintenance Manual: Test Set, Antenna AN/ARM-115

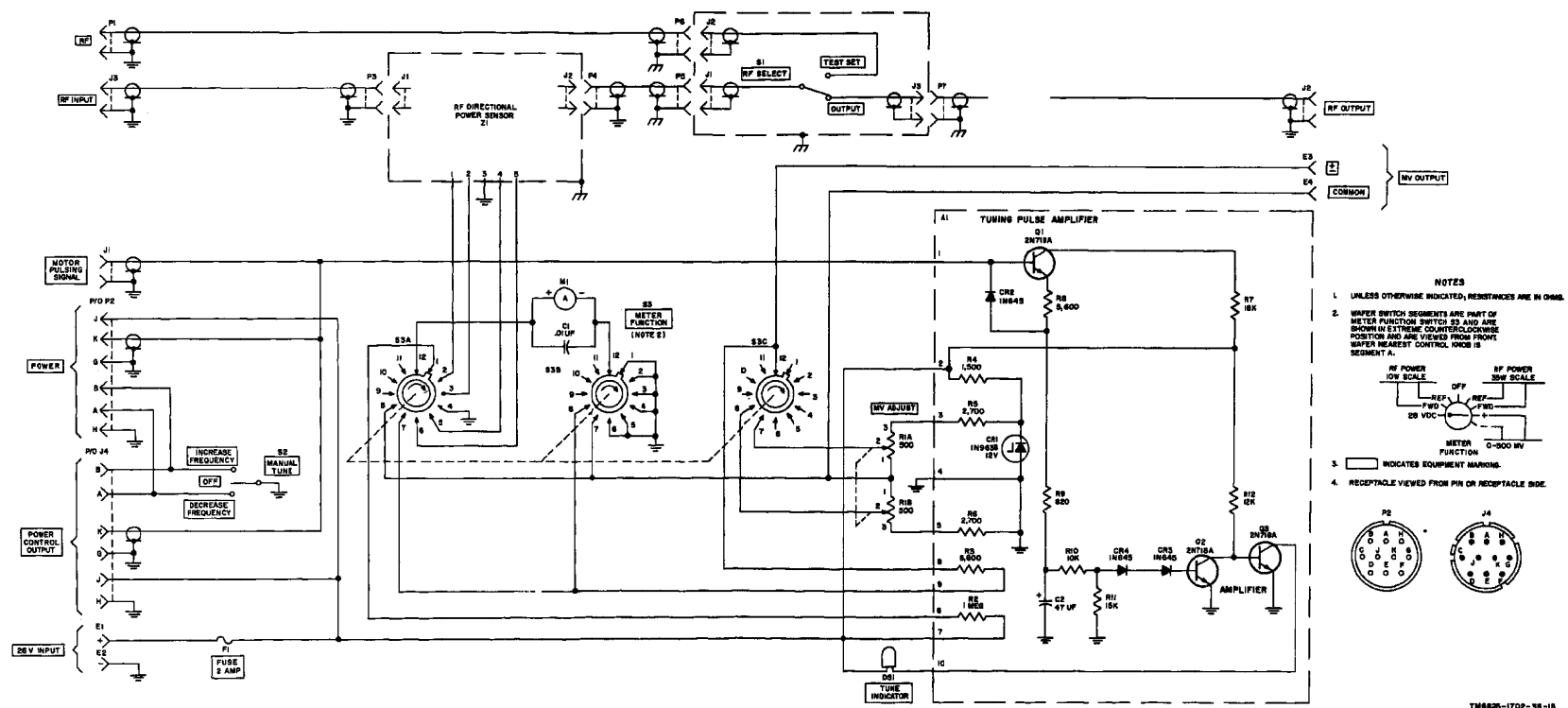
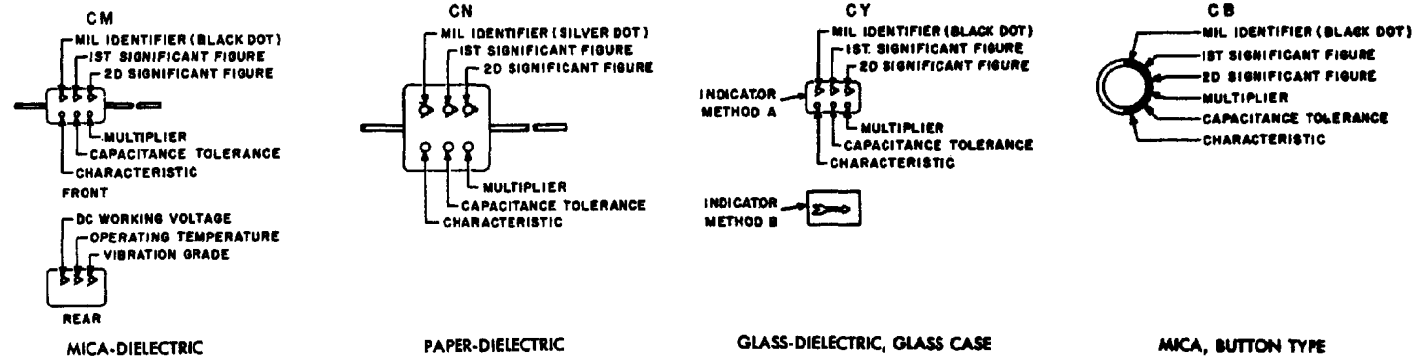

Figure 3-8. Color code marking for MIL-STD capacitors.

COLOR CODE MARKING FOR MILITARY STANDARD CAPACITORS

GROUP I Capacitors, Fixed, Various-Dielectrics, Styles CM, CN, CY, and CB



GROUP II Capacitors, Fixed Ceramic-Dielectric (General Purpose) Style CK

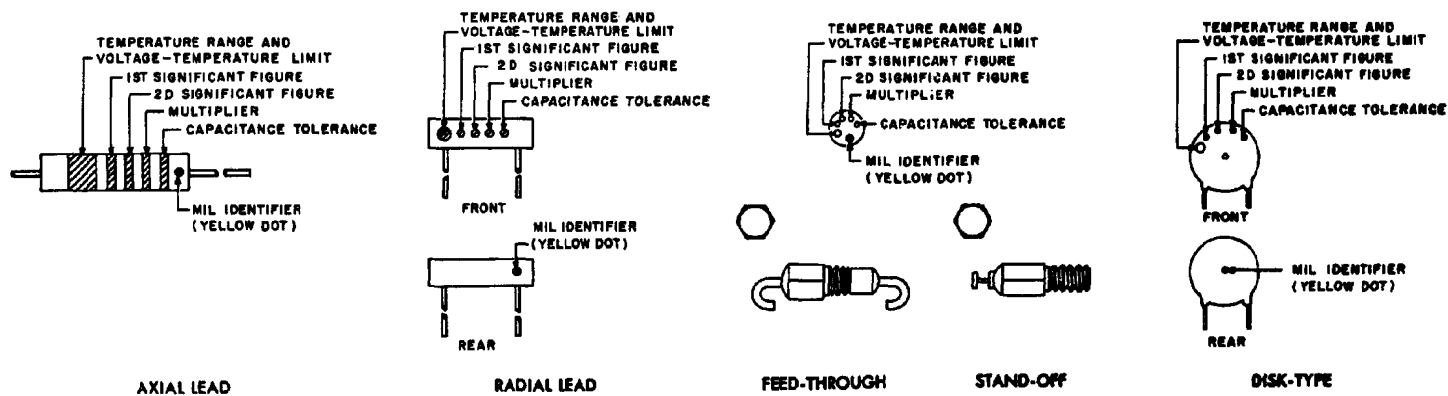

GROUP III Capacitors, Fixed, Ceramic-Dielectric (Temperature Compensating) Style CC

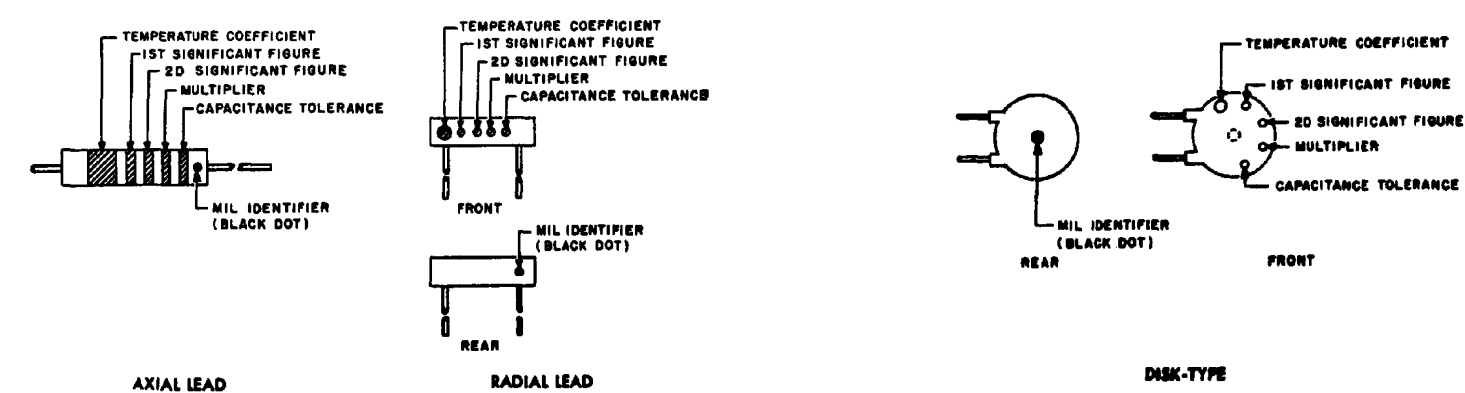

COLOR CODE TABLES

TABLE I - For use with Group I, Styles CM, CN, CY and CB

COLOR	MIL ID	1st SIG FIG	2nd SIG FIG	MULTIPLIER ¹	CAPACITANCE TOLERANCE				CHARACTERISTIC ²				DC WORKING VOLTAGE	OPERATING TEMP. RANGE	VIBRATION GRADE
					CM	CN	CY	CB	CM	CN	CY	CB	CM	CM	CM
BLACK	CM, CY CB	0	0	1			± 20%	± 20%		A				-55° to +70°C	10-55 cps
BROWN		1	1	10					B	E	B				
RED		2	2	100	± 2%		± 2%	± 2%	C		C			-55° to +85°C	
ORANGE		3	3	1,000		± 30%			D		D	300			
YELLOW		4	4	10,000					E					-55° to +125°C	10-2,000 cps
GREEN		5	5		± 5%				F			500			
BLUE		6	6											-55° to +150°C	
PURPLE (VIOLET)		7	7												
GREY		8	8												
WHITE		9	9												
GOLD				0.1			± 5%	± 5%							
SILVER	CN				± 10%	± 10%	± 10%	± 10%							

TABLE II - For use with Group II, General Purpose, Style CK

COLOR	TEMP. RANGE AND VOLTAGE - TEMP. LIMITS ³	1st SIG FIG	2nd SIG FIG	MULTIPLIER ¹	CAPACITANCE TOLERANCE	MIL ID
BLACK		0	0	1	± 20%	
BROWN	AW	1	1	10	± 10%	
RED	AX	2	2	100		
ORANGE	BX	3	3	1,000		
YELLOW	AV	4	4	10,000		CK
GREEN	CZ	5	5			
BLUE	BV	6	6			
PURPLE (VIOLET)		7	7			
GREY		8	8			
WHITE		9	9			
GOLD						
SILVER						

TABLE III - For use with Group III, Temperature Compensating, Style CC

COLOR	TEMPERATURE COEFFICIENT ⁴	1st SIG FIG	2nd SIG FIG	MULTIPLIER ¹	CAPACITANCE TOLERANCE		MIL ID
					Capacitances over 10uf	Capacitances 10uf or less	
BLACK	0	0	0	1		± 2.0uf	CC
BROWN	-30	1	1	10	± 1%		
RED	-80	2	2	100	± 2%	± 0.25uf	
ORANGE	-150	3	3	1,000			
YELLOW	-220	4	4				
GREEN	-320	5	5		± 5%	± 0.5uf	
BLUE	-470	6	6				
PURPLE (VIOLET)	-750	7	7				
GREY		8	8	0.01			
WHITE		9	9	0.1	± 10%		
GOLD	+100					± 1.0uf	
SILVER							

1. The multiplier is the number by which the two significant (SIG) figures are multiplied to obtain the capacitance in uf.
2. Letters indicate the Characteristics designated in applicable specifications: MIL-C-5, MIL-C-91, MIL-C-11272, and MIL-C-10950 respectively.
3. Letters indicate the temperature range and voltage-temperature limits designated in MIL-C-11015.
4. Temperature coefficient in parts per million per degree centigrade.

Figure 5-3. Test set overall schematic diagram.

By Order of the Secretary of the Army:

Official:

KENNETH G. WICKHAM,
*Major General, United States Army,
The Adjutant General.*

HAROLD K. JOHNSON,
*General, United States Army,
Chief of Staff.*

Distribution:

To be distributed in accordance with DA Form 12-36 requirements for Direct and General Support maintenance, UH-1B and UH-1D aircraft.

RECOMMENDED CHANGES TO EQUIPMENT TECHNICAL PUBLICATIONS



THEN...JOT DOWN THE DOPE ABOUT IT ON THIS FORM. CAREFULLY TEAR IT OUT, FOLD IT AND DROP IT IN THE MAIL.

SOMETHING WRONG WITH PUBLICATION

FROM: (PRINT YOUR UNIT'S COMPLETE ADDRESS)

DATE SENT

PUBLICATION NUMBER

PUBLICATION DATE

PUBLICATION TITLE

BE EXACT PIN-POINT WHERE IT IS

PAGE NO.

PARA-GRAPH

FIGURE NO.

TABLE NO.

IN THIS SPACE, TELL WHAT IS WRONG AND WHAT SHOULD BE DONE ABOUT IT.

TEAR ALONG PERFORATED LINE

PRINTED NAME, GRADE OR TITLE AND TELEPHONE NUMBER

SIGN HERE

The Metric System and Equivalents

Linear Measure

1 centimeter = 10 millimeters = .39 inch
 1 decimeter = 10 centimeters = 3.94 inches
 1 meter = 10 decimeters = 39.37 inches
 1 dekameter = 10 meters = 32.8 feet
 1 hectometer = 10 dekameters = 328.08 feet
 1 kilometer = 10 hectometers = 3,280.8 feet

Weights

1 centigram = 10 milligrams = .15 grain
 1 decigram = 10 centigrams = 1.54 grains
 1 gram = 10 decigrams = .035 ounce
 1 dekagram = 10 grams = .35 ounce
 1 hectogram = 10 dekagrams = 3.52 ounces
 1 kilogram = 10 hectograms = 2.2 pounds
 1 quintal = 100 kilograms = 220.46 pounds
 1 metric ton = 10 quintals = 1.1 short tons

Liquid Measure

1 centiliter = 10 milliliters = .34 fl. ounce
 1 deciliter = 10 centiliters = 3.38 fl. ounces
 1 liter = 10 deciliters = 33.81 fl. ounces
 1 dekaliter = 10 liters = 2.64 gallons
 1 hectoliter = 10 dekaliters = 26.42 gallons
 1 kiloliter = 10 hectoliters = 264.18 gallons

Square Measure

1 sq. centimeter = 100 sq. millimeters = .155 sq. inch
 1 sq. decimeter = 100 sq. centimeters = 15.5 sq. inches
 1 sq. meter (centare) = 100 sq. decimeters = 10.76 sq. feet
 1 sq. dekameter (are) = 100 sq. meters = 1,076.4 sq. feet
 1 sq. hectometer (hectare) = 100 sq. dekameters = 2.47 acres
 1 sq. kilometer = 100 sq. hectometers = .386 sq. mile

Cubic Measure

1 cu. centimeter = 1000 cu. millimeters = .06 cu. inch
 1 cu. decimeter = 1000 cu. centimeters = 61.02 cu. inches
 1 cu. meter = 1000 cu. decimeters = 35.31 cu. feet

Approximate Conversion Factors

To change	To	Multiply by	To change	To	Multiply by
inches	centimeters	2.540	ounce-inches	newton-meters	.007062
feet	meters	.305	centimeters	inches	.394
yards	meters	.914	meters	feet	3.280
miles	kilometers	1.609	meters	yards	1.094
square inches	square centimeters	6.451	kilometers	miles	.621
square feet	square meters	.093	square centimeters	square inches	.155
square yards	square meters	.836	square meters	square feet	10.764
square miles	square kilometers	2.590	square meters	square yards	1.196
acres	square hectometers	.405	square kilometers	square miles	.386
cubic feet	cubic meters	.028	square hectometers	acres	2.471
cubic yards	cubic meters	.765	cubic meters	cubic feet	35.315
fluid ounces	milliliters	29.573	cubic meters	cubic yards	1.308
pints	liters	.473	milliliters	fluid ounces	.034
quarts	liters	.946	liters	pints	2.113
gallons	liters	3.785	liters	quarts	1.057
ounces	grams	28.349	liters	gallons	.264
pounds	kilograms	.454	grams	ounces	.035
short tons	metric tons	.907	kilograms	pounds	2.205
pound-feet	newton-meters	1.356	metric tons	short tons	1.102
pound-inches	newton-meters	.11296			

Temperature (Exact)

°F Fahrenheit temperature 5/9 (after subtracting 32) Celsius temperature °C

PIN: 016340-003